

# The determination of a torque measuring devices susceptibility to bending effects when using an unsupported calibration beam.

Barry C. Pratt  
Head of Laboratory  
Norbar Torque Tools Ltd  
Beaumont Road  
Banbury  
Oxfordshire  
OX16 1XJ  
United Kingdom

Phone: + 44 (0) 1295 270 333  
E-mail: [bpratt@norbar.com](mailto:bpratt@norbar.com)

**Abstract** – Unsupported calibration beams coupled directly to a transducer are used in industry for reasons of cost and simplicity. They can be used to calibrate transducers to the highest levels of classification, however they do induce bending effects [1] into the device and this should be considered as part of the uncertainty calculation. A double load test is used to determine the susceptibility of a torque transducer to bending and to provide a bending contribution in the uncertainty calculation. This method is given in the NPL good practice guide No. 107 “Guide to the calibration and testing of torque transducers “[2].

## **Introduction**

Unsupported Calibration Beams are flexible and easy to use and in many instances replicate the way the torque measuring device is subsequently used. This makes them well suited for calibration of the many forms of torque measuring devices found in industry from 0.05 N·m – 1500 N·m, their use being inappropriate only if the device under calibration exhibits a high susceptibility to bending effects.

It is best practice to use a beam with a capacity that is commensurate with the transducer being calibrated and ideally the weight of the beam should be as light as possible. The distance between the beam and transducer should be kept to a minimum and alignment, couplings and fixtures should be considered. A calibration range of 10% - 100% of full scale is preferred as the transducers sensitivity (mV/V/N·m) can increase sharply below the 10% mark due to the effect of bending.

It is also best practice to calibrate the transducer in a symmetrical manner to minimise the influence from bending

The characteristics of how a transducer behaves is an important factor to consider when using unsupported beams and the data from a double loading test provides a measure of this as well as quantifying the bending characteristics.

## **General requirements**

The normal arrangement when using an unsupported calibration beam is shown in figure 1. Depending on the individual transducer adaptors may or may not be used. Where possible it is always best to connect the beam directly to the transducer in order to minimise any slack in the coupling of the square drives, and the transducer should be held as rigidly as possible in the calibration fixture. In this configuration the weight of the applied masses for a given torque plus the weight of the calibration beam induce bending effects into the transducer.

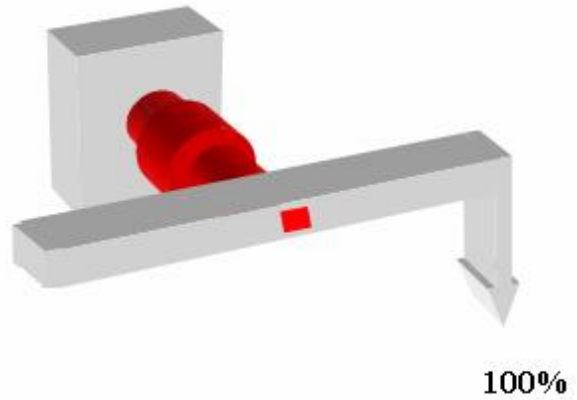
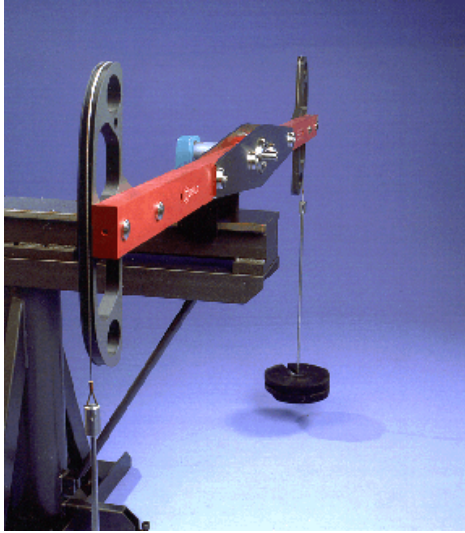

**Figure 1. Unsupported Calibration beam and schematic for single loading**

### **Method**

In order to determine the bending effects a double loading test is undertaken to determine the susceptibility of the transducer to bending loads. This involves loading both ends of the calibration beam as shown in figure 2, so that the same torques are applied as in a normal calibration (figure 1) but using double the load.

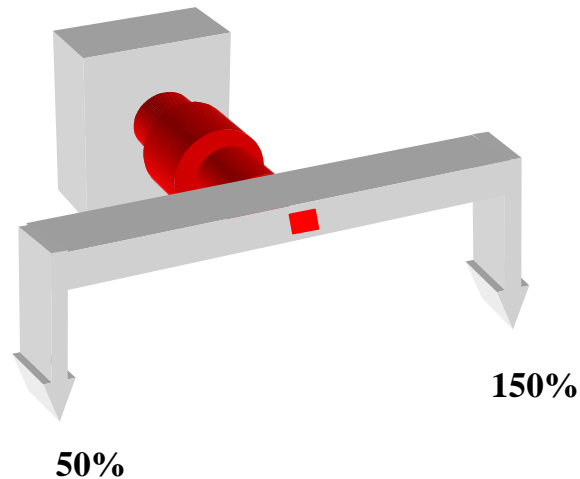

**Figure 2. Schematic for the double load test.**

The calibration is based on BS 7882:2008[3] using four different mounting positions each rotated 90° about the measurement axis. At each mounting position one series of increasing torques is applied to the transducer.

At each calibration torque the deflection is recorded and then an additional 50% of the load is applied on each side of the beam at exactly the same time, so that 150 % of the applied load is in the direction the torque is to be applied and 50 % of the load is in the opposite

direction, the deflection is then recorded. The additional load is removed and the next increasing torque is applied.

The maximum difference between the single and double loading deflections at each increasing calibration torque is calculated across the measurement series at each orientation.

The difference between the single and double loading deflections is expressed as a percentage of the single loading deflection. The bending parameter is taken as the maximum of these differences.

$$\text{Bending} = \text{Max} \left[ \frac{d_{doub} - d_{sing}}{d_{sing}} \times 100 \right]$$

where

$d_{sing}$  is the deflection for the single loading series

$d_{doub}$  is the deflection for the double loading series

**Table 1. worked example of bending evaluation; deflection in mV/V**

Applied torque N·m	deflection 0° $d_{sing}$	deflection 0° D/Load $d_{doub}$	% bending	Applied torque N·m	deflection 90° $d_{sing}$	deflection 90° D/Load $d_{doub}$	% bending
0	0.00069	0.00069	n/a	0	0.00007	0.00007	n/a
10	0.20157	0.20165	0.040	10	0.20087	0.20083	-0.020
20	0.40236	0.40255	0.047	20	0.40158	0.4015	-0.020
40	0.80414	0.80452	0.047	40	0.80312	0.80294	-0.022
60	1.20595	1.20654	0.049	60	1.20472	1.20455	-0.014
80	1.60793	1.6087	0.048	80	1.6065	1.60624	-0.016
100	2.00988	2.01089	0.050	100	2.00824	2.00791	-0.016

Applied torque N·m	deflection 180° $d_{sing}$	deflection 180° D/Load $d_{doub}$	% bending	Applied torque N·m	deflection 270° $d_{sing}$	deflection 270° D/Load $d_{doub}$	% bending
0	-0.00014	-0.00014	n/a	0	0.00037	0.00037	n/a
10	0.20068	0.20061	-0.035	10	0.20129	0.20135	0.030
20	0.40137	0.4012	-0.042	20	0.40211	0.40223	0.030
40	0.80288	0.80252	-0.045	40	0.80385	0.80408	0.029
60	1.20445	1.20391	-0.045	60	1.20565	1.20607	0.035
80	1.60611	1.60545	-0.041	80	1.60756	1.60795	0.024
100	2.00777	2.007	-0.038	100	2.00943	2.01	0.028

Maximum bending = 0.05% between 10% and 100% of full scale.

### Analysis of work example

Figures 3 and 4 show the output at 20% and 100% of full scale deflection for single and double loading, using the values for each applied torque measured in the four positions. The transducer exhibits a sine wave geometry. The bending influences the output and effects the span of the reproducibility, though because of its symmetric nature it has little effect on the mean output. However It should be noted that not all transducers behave in such a symmetrical manner and where this occurs consideration needs to be given to the differences between the mean values.

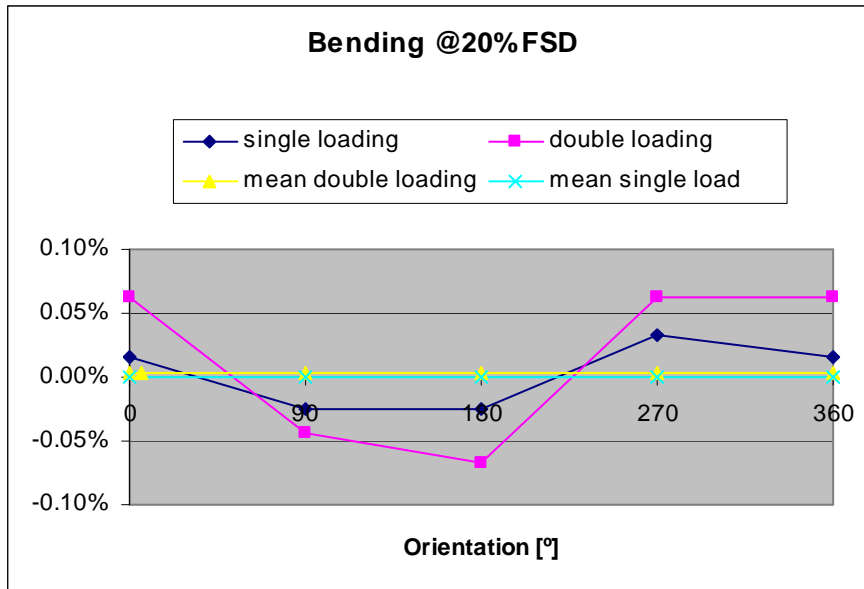

Figure 3. double load test at 20% of full scale deflection.

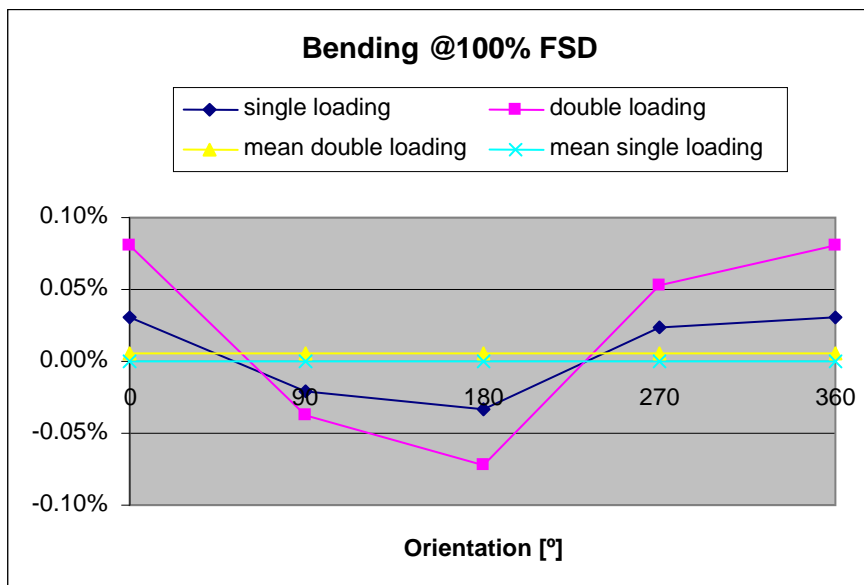
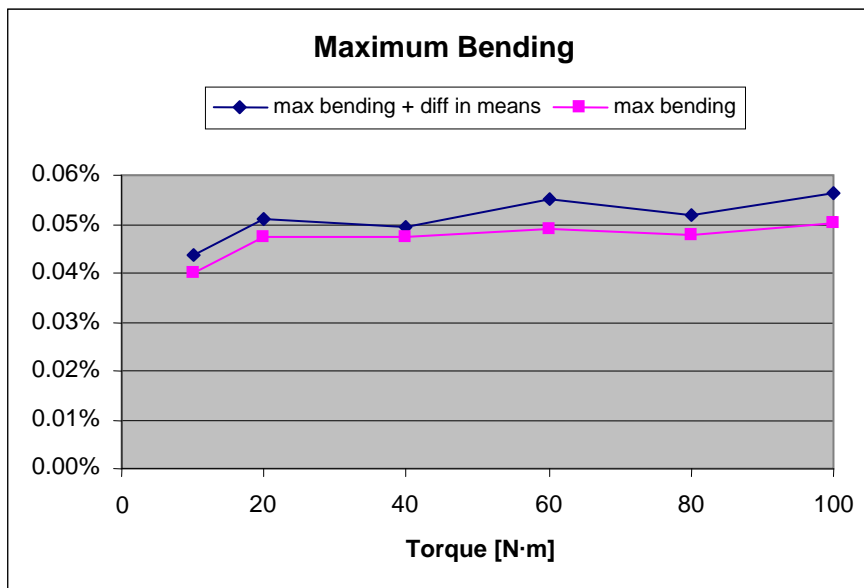

Figure 4. double load test at 100% of full scale deflection.

The maximum bending at each applied torque is shown in figure 5. The maximum bending plus the difference in the mean values between the single and double loading is also shown.



**Figure 5. Maximum bending.**

The bending parameter is established at 0.05% and can now be used in the calibration uncertainty calculation.

The characteristics of how a transducer behaves is an important factor to consider when using unsupported beams and the data from the double loading test provides a measure of how symmetrical its performance is. Ideally the bending should be equal and opposite when turned through 180° and therefore give a similar mean value between single and double loading.

A practical solution for transducers whose output is unsymmetrical is to add the difference between the mean values to the bending parameter.

### **Simplified bending evaluation**

Depending on what is known about the design and performance of a particular type of transducer a simplified bending test may be used to estimate its susceptibility to bending effects. The basic method describe above is used but at full scale in two planes only. The largest value is taken as the bending parameter which is then assumed to be linear across the calibrated range of the transducer; bending linearity can be checked by repeating the test at 10% or 20% of full scale if deemed necessary.

This is a practical cost effective approach to assessing bending which can be performed at the end of a calibration without the process becoming to time consuming. However it should be remembered that the four plane evaluation provides a comprehensive assessment of transducers behaviour in respect to bending and how it reacts to an unsupported calibration beam.

### **Conclusion**

When using unsupported calibration beams it is best practice to include an allowance for bending effects in the calibration uncertainty calculation. It is also important to check that the bending allowance encompasses any increase in the transducers sensitivity (m/V/V/N·m) for readings in the range 2% - 10% of full scale deflection. With bending and sensitivity effects taken into consideration it is possible to perform fit for purpose calibrations to high levels of accuracy over the transducers calibrated range.

## WORK SHEET FOR BENDING EFFECTS

CAPACITY
SERIAL No
MODEL

DATE	
------	--

NAME	

Beam
Lead
Adaptor

		preload	
1	100%		
2	100%		
3	100%		

Note preload to 100% before starting each calibration run

Temp			
Applied %	deflection 0°	deflection 0° D/Load	% bending
0			n/a
2			
5			
10			
20			
40			
60			
80			
100			
0			
Temp			

Temp			
Applied %	deflection 90°	deflection 90° D/Load	% bending
0			n/a
2			
5			
10			
20			
40			
60			
80			
100			
0			
Temp			

Temp			
Applied %	deflection 180°	deflection 180° D/Load	% bending
0			n/a
2			
5			
10			
20			
40			
60			
80			
100			
0			
Temp			

Temp			
Applied %	deflection 270°	deflection 270° D/Load	% bending
0			n/a
2			
5			
10			
20			
40			
60			
80			
100			
0			
Temp			

## References

- [1] Pratt B, Robinson A, 2006 A comparison between supported and unsupported beams for use in static torque calibrations. *Proceedings of the 18<sup>th</sup> Imeko World Congress*, Rio de Janeiro.
- [2] Robinson A, 2008 Guide to the calibration and testing of torque transducers. NPL. National measurement good practice guide No.107.
- [3] BS7882:2008; Calibration and classification of torque measuring devices